

## Article info

Received on: 27.02.2023

Accepted on: 28.03.2023

Published on: 31.03.2023

doi: <https://doi.org/10.52688/ASP91488>

## Research Article

# Design of a Low-Cost Smart Frequency Meter

Ahmed M. T. Ibraheem Al-Naib<sup>1,\*</sup><sup>1</sup> Dep. of Electrical Power Technologies Eng., Engineering Technical College, Mosul, Northern Technical University, Iraq\* [ahmed\\_alnaib2018@ntu.edu.iq](mailto:ahmed_alnaib2018@ntu.edu.iq)

## ABSTRACT

An important step toward managing energy and costs in an effective and cost-saving manner is to monitor electrical equipment that consume electricity in the proper manner. The characteristics of an electrical power supply can alter in many different ways when electrical devices are used. During the use of electrical devices, the parameters of an electrical power system change in a lot of ways. These changes in the parameters required to be measured using accrued meters. This paper presents the design and implementation of a frequency meter based on Arduino for a three-phase synchronous generator. In addition, it was used to detect the abnormal operation of a three-phase synchronous generator (at low and high frequencies). The proposed frequency meter displayed the measured parameters and the protection status of each data point directly on the LCD and took a serial print of the Arduino software program on the PC via a USB cable. A smart monitoring system for these operation conditions was designed using a Bluetooth module. One sensor has been used with the frequency meter: an AC voltage sensor type ZMPT101b. The frequency has been measured utilizing the ac voltage sensor signal, i.e., without using any external zero crossing detector hardware circuit.

**Keywords:** Monitoring system, Cost-efficient, Frequency, Arduino, and Sensors

## INTRODUCTION

The primary component of the generating system, where they provide the necessary electricity to the clients, is thought to be the synchronous generators.

The generator voltage, current, and frequency will fluctuate above and below the safe limits due to the many abnormal grid situations, such as faults, unbalanced loads, and the inability to maintain the minimal level of power needs. The effectiveness, efficiency, and dependability of the power system will be significantly impacted by this unwanted work.

Currently, digital electronics energy measurement is continuously replacing existing technology of electro-mechanical meters. A wireless digital power meter will definitely offer greater convenience for the meter-reading task [1]. PLC and Arduino are getting more and more attention in this field (i.e., measurement instruments and monitoring systems) due to their flexible features and rich library functions. It is user robust, fast and at the same time user friendly. Many approaches have been used to measure, monitor, and detect faults in electrical systems based on microcontrollers. Khan et al. designed a training system that uses both electro-mechanical and microcontroller-based (Arduino) relays simultaneously in such a way that the electrical system could be switched to either an electro-mechanical or microcontroller-based relay setup. This system also displays the current magnitude of the fault and the time required by the relay to clear the fault [2-7]. In [8], an experimental study had been considered to monitor and measure the electrical quantities using Arduino. The authors in [9] designed a system based on an Atmega328P microcontroller to measure the voltage of a particular phase and switch to another phase if the measured voltage is over or under the voltage condition with a range from 160 to 220 volts. Arduino-GSM-based power system protection has been implemented as an educational test pinch [10] for different electrical quantities. Shivkumar et al. [11] designed a frequency protection relay and power factor correction system based on Arduino. The authors in [11] have used Arduino Uno to practically implement over- and under-current protection for a renewable energy system. A monitoring and protection system for distribution transformers has been implemented practically using Arduino, GSM, and GPS; this system records the current, voltage, oil pressure, and ambient temperature for the transformers [13-14]. In this paper, a protection and smart monitoring system for one phase of a synchronous generator is designed and practically implemented. Low- and high-frequency parameters were detected. Three types of monitoring the data were used: a serial monitor in IDE Arduino software, a 16\*2 LCD, and an Android app that reserved the data via a Bluetooth module.

---

**\*Corresponding author**

Ahmed M. T. Ibraheem Al-Naib,

Dep. of Electrical Power Technologies Eng., Engineering Technical College, Mosul, Northern Technical University, Iraq

e-mail: [ahmed\\_alnaib2018@ntu.edu.iq](mailto:ahmed_alnaib2018@ntu.edu.iq)

## PROPOSED MONITORING & PROTECTION SYSTEM

Figure 1 shows the proposed system based on Arduino. The system consists of three main parts: sensors, controller (Arduino), and monitoring part. Only one sensor has been used (the voltage sensor). Arduino-type Mega 2560, which has a built-in ATmega328 microcontroller. It has 54 digital I/P and O/P pins, 16 analog I/P, 4 UARTs (hardware serial ports), a 16 MHz crystal oscillator, and an Analog to Digital Converter (ADC) with 10-bit resolution. It encloses everything needed to support the microcontroller; it is simply programmed by the Arduino IDE software via a USB connection [15-18]. In this work, three types of monitoring systems are used.

The first uses the serial monitor property for monitoring the data on the PC, in which case the USB cable of the Arduino must always be connected to the PC. The second approach is achieved by using a 2\*16 LCD with an I2C interfacing model for directly displaying the data. The last method is done by using the Bluetooth module to send all measurements to a mobile device for display via a mobile application (serial monitor).

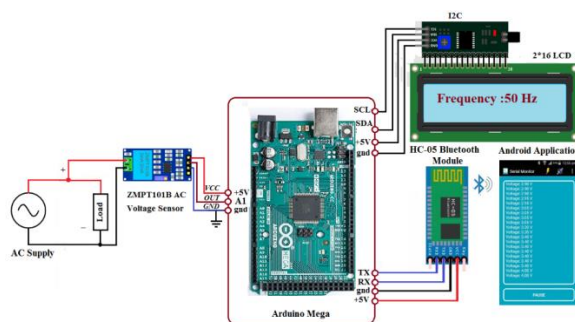

Figure 1. Proposed monitoring & protection system.

## VOLTAGE SENSOR

The ZMPT101B sensor unit is an AC-type voltage sensor based on a built-in voltage transformer. It has high accuracy and reliability for voltage and power measurement, and a wide range of measurement (0-250 AC voltage) [19-34]. It is very easy to use and build, with a multi-turn trim potentiometer for adjusting the ADC output. The module reads the signal that will be measured (220 V phase voltage) in the current work with a peak value of 311 V [34-40]. The built-in voltage transformer reduces it to 2.5 V (peak). Then a 2.5 V offset has been inserted to shift the signal to a positive level where the Arduino ADC can be detected, as shown in Figure 2.

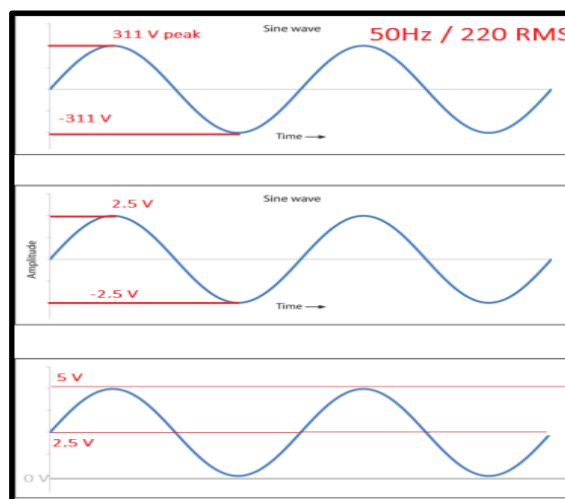

Figure 2. Operation of single-phase ZMPT101B voltage sensor.

## FREQUENCY MEASUREMENT

The frequency is measured based on the AC voltage signal of the zmp101B sensor (or can be based on the AC signal of the load current signal of the load current sensor). Whereas the AC voltage signal is compared with the zero-reference value to convert the sine wave signal into a square wave (if the AC voltage signal is  $> 0$ , then the square wave signal equals 1, if the AC voltage signal

### \*Corresponding author

Ahmed M. T. Ibraheem Al-Naib,

Dep. of Electrical Power Technologies Eng., Engineering Technical College, Mosul, Northern Technical University, Iraq

e-mail: [ahmed\\_alnaib2018@ntu.edu.iq](mailto:ahmed_alnaib2018@ntu.edu.iq)

is  $< 0$ , then the square wave signal equals 0), as shown in Figure 3 (a). The duration of the square wave will be measured between each of its rising edges. The frequency is equal to the inverse value of this time duration value, as shown in the code in Figure 3 (b).

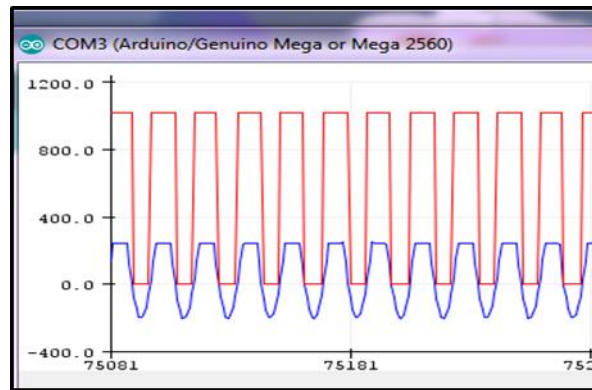

(a): Frequency measurement

```
//-----Frequency Measurement-----//
for(int f=0;f<25000;f++)
{ float sensor_voltage = analogRead (A1);
if ((sensor_voltage -512) > 0){
digitalWrite(7,HIGH);} //digital pin 7 is high
if ((sensor_voltage -512) < 0){
digitalWrite(7,LOW);} //digital pin 7 is LOW
currentstate = digitalRead(2); // read square wave form pin 7
if( prevstate != currentstate) // If there is change in input
{ if( currentstate == HIGH) // If input only changes from LOW to HIGH
{ duration = ( micros() - prevmicros ); // Time difference in microsecond
freq = (1000000/duration); // Frequency = (1/ time millis)*1000*1000;
prevmicros = micros(); } // store time for next revolution calculation
prevstate = currentstate; // store this scan (prev scan) data for next scan
if( ( millis()-lodrefresh ) >= 1000 )
{Serial.print("Frequency (Hz) = "); Serial.println(freq);
lodrefresh = millis(); } }
```

(b): Frequency measurement code process

Figure 3. (a) and (b) Frequency measurement.

## PROTECTION PROCESS

After measuring the frequency of synchronous generator, the values of these parameters will be displayed on the (serial monitor on PC, Mobile application via Bluetooth, and 2x16 characters LCD). Then a comparison between measured and threshold values is made for monitoring and protecting the system as follows:

In general; there are two main levels for acceptable frequency limits; the first one is the "Operational limit", at which the frequency tolerance is equal to  $\pm 0.2$  Hz (i.e. 49.8 Hz to 50.2 Hz), and the second one, is the "Statutory limit", at which the frequency tolerance equals to  $\pm 0.5$  Hz (i.e. 49.5 Hz and 50.5 Hz) as shown in Figure 4 [19].

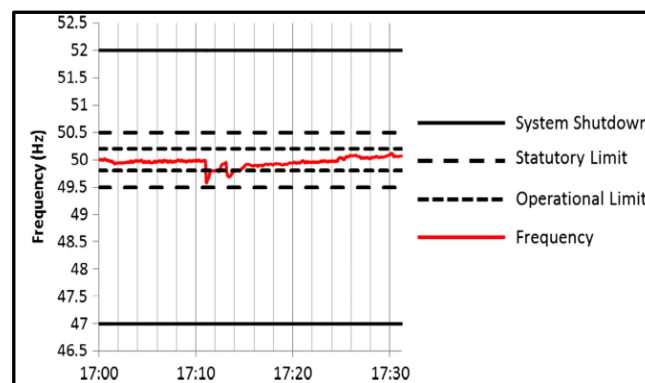

Figure 4. The statutory and operational frequency limits.

### \*Corresponding author

Ahmed M. T. Ibraheem Al-Naib,  
 Dep. of Electrical Power Technologies Eng., Engineering Technical College, Mosul, Northern Technical University, Iraq  
 e-mail: [ahmed\\_alnaib2018@ntu.edu.iq](mailto:ahmed_alnaib2018@ntu.edu.iq)

In the current work, the second frequency criteria limit (statutory limit) has been considered. If the frequency value is greater than 50.5 Hz, a "High Frequency" message will be displayed on the (Serial monitor on PC and mobile application via Bluetooth) and an "HF" message will appear on the LCD. Also, in the case of a frequency lower than 49.5 Hz, a "Low Frequency" message will be displayed on the (Serial monitor on PC, and mobile application via Bluetooth) and an "LF" message will appear on the LCD, as shown in Figure 5.

```

if(freq <= 49.500){Serial.println("Low Frquency");
                    blue.println("Low Frquency");
                    lcd.setCursor(14,0);lcd.print("LF");}
if(freq >= 50.500){Serial.println("High Frquency");
                    blue.println("High Frquency");
                    lcd.setCursor(14,0);lcd.print("HF");}

```

Figure 5. Abnormal frequency values message code.

## EXPERIMENTAL RESULTS AND DISCUSSION

Figure 6 shows the experimental setup of the proposed monitoring and protection system for one phase of a three-phase alternator based on Arduino.

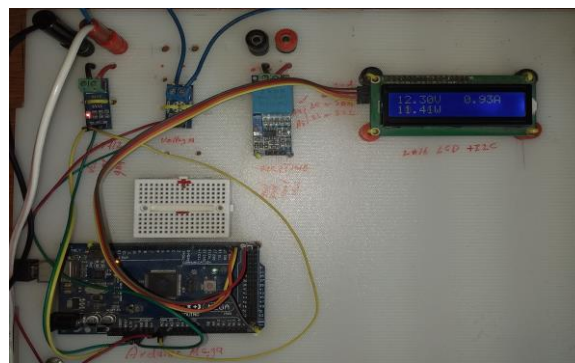
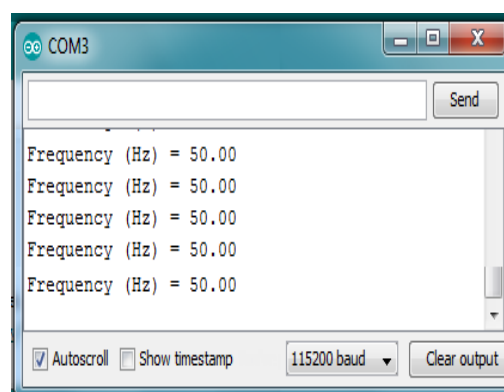

Figure 6. Arduino board with sensors.

The performance of the system has been tested under different conditions, and the measured frequency is directly displayed on the serial monitor on the PC. Figure 7. Normal operation, high-frequency cases, and low-frequency cases are depicted in Figures 7.a, 7.b, and 7.c, respectively.

At the same time, a Bluetooth module has been used to send the same data to be displayed on the Android app, as shown in Figure 8, with the same sequence of serial monitor displaying; this property adds flexibility for monitoring the system. At the same time, 2\*16 LCD characters were used for directly mentoring these data and a protection message.



(a) Normal operation

### \*Corresponding author

Ahmed M. T. Ibraheem Al-Naib,  
 Dep. of Electrical Power Technologies Eng., Engineering Technical College, Mosul, Northern Technical University, Iraq  
 e-mail: [ahmed\\_alnaib2018@ntu.edu.iq](mailto:ahmed_alnaib2018@ntu.edu.iq)

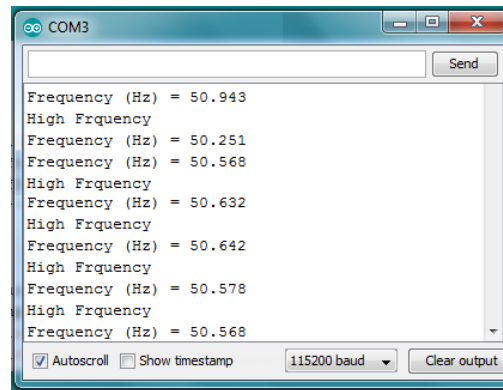

(b) High Frequency

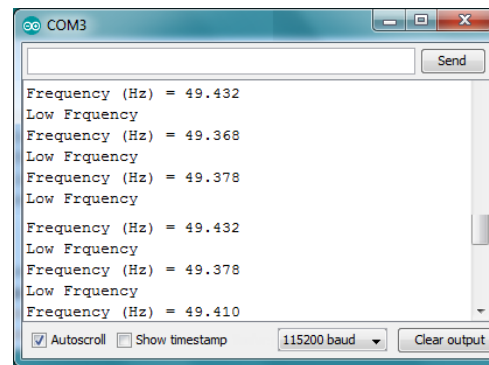

(c) Low Frequency

Figure 7. Serial monitor screen–shoot of measuring data at various normal and abnormal cases.

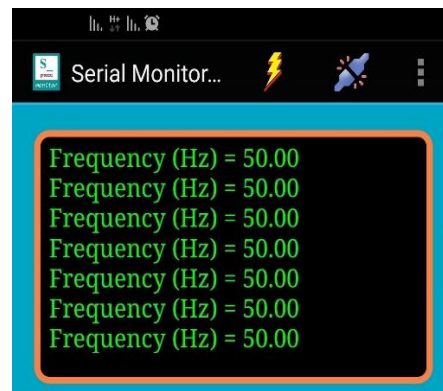

(a) Normal operation

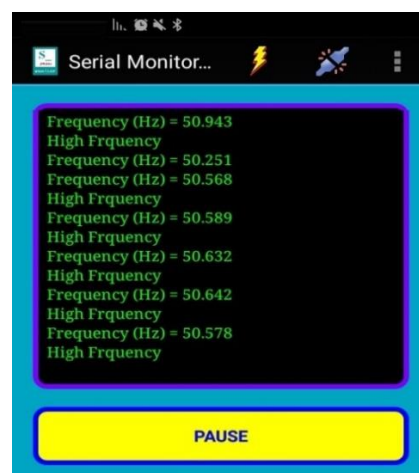

(b) High Frequency

**\*Corresponding author**

Ahmed M. T. Ibraheem Al-Naib,  
 Dep. of Electrical Power Technologies Eng., Engineering Technical College, Mosul, Northern Technical University, Iraq  
 e-mail: [ahmed\\_alnaib2018@ntu.edu.iq](mailto:ahmed_alnaib2018@ntu.edu.iq)

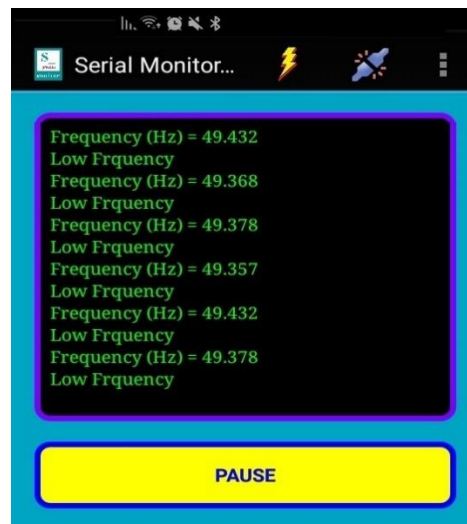

(b) Low Frequency

**Figure 8. Serial Monitor (Mobile application) screen –shoot of measuring data at various normal and abnormal cases.**

## CONCLUSIONS

The proposed system based on Arduino can continuously monitor the frequency with high accuracy and detect all the abnormal operations of the synchronous generator. If these parameters exceeded the threshold value, which was previously set in the proposed software, an alarm message about the abnormal operation, in addition to a protection scheme, could operate and trip the load. The Arduino Mega has a wide application in controlling power systems due to its low price and simple circuitry compared to other controllers, in addition to its reliability, flexibility in use. In this work, only one sensor is used (voltage); the frequency is measured without using an external circuit (i.e., zero crossing detectors). In future work; power factor, power consumption, and energy measurement, in addition to abnormal states (such as unbalanced load and phase failure), can be developed for the proposed system (i.e., with only two used sensors).

## REFERENCES

- [1] Shahidi S, Gaffar M A and Salim K M, 2013 "Design and implementation of digital energy meter with data sending capability using GSM network," IEEE 2nd Int. Conf. on Adv. In Elect. Eng., Dhaka, pp. 203-206.
- [2] Khan B A, Ashraf H M, Hamid S, Asif R M and Bashir U, 2019, "Implementation of micro controller based electromechanical over current relay for radial feeder protection," IEEE Int. Conf. on Eng. and Emerging Tech. (ICEET), Lahore, Pakistan, pp. 1-6.
- [3] Ibraheem, A., Ibrahim, M., & Shanshal, A. (2020, September). PLC Based Overcurrent Protection of Three-phase Transmission Line. In Proceedings of the 1st International Multi-Disciplinary Conference Theme: Sustainable Development and Smart Planning, IMDC-SDSP 2020, Cyperspace, 28-30 June 2020.
- [4] Altaee, O. M., Alnaib, A. I., & Aljawady, N. A. A. (2018). Design and Realization of a Stepper Motor Driver with PLC. Al-Kitab J. Pure Sci, 2(1).
- [5] Ahmed M. T. Ibraheem, "Design an Industrial Robot Arm Controller Based on PLC" PRZEGLĄD ELEKTROTECHNICZNY, Vol. 2022, No 7, PP 105-109.
- [6] Laith A. KHALAF, Omar T. MAHMOOD, Ahmed M. T. IBRAHEEM, " Smart Speed Control of BLDC Motor Using Programmable Logic Controller" PRZEGLĄD ELEKTROTECHNICZNY, Vol. 2023, No 1.
- [7] Alnaib, A. M. I., Altaee, O. T. M., & Al-jawady, N. A. A. B. (2018, May). Plc controlled multiple stepper motors using various excitation methods. In 2018 International Conference on Engineering Technology and their Applications (IICETA) (pp. 54-59). IEEE.
- [8] MT Ibraheem Al-Naib, A., & Abdullah Hamad, B. (2022). A Cost-Effective Method for Power Factor Metering Systems. International journal of electrical and computer engineering systems, 13(5), 409-415.
- [9] Abuh A and Orukpe P E, 2019, "Microcontroller based automatic power selection switch", IOSR J. of Elect. and Electro. Eng., vol. 14, no. 1, pp. 35-41.
- [10] Barkat H S E and Mahdad B, 2018 "An Experimental Educational Platform Based Arduino-GSM for Power System Protection", IEEE Int. Conf. on Commun. and Elect. Eng., El Oued, Algeria, pp. 1-6.
- [11] Chaudhari S S, Shirsat D A et al, 2018, "Under and over frequency relay with automatic power factor control using Arduino Uno", Int. J. for Emerging Research & Develop., vol. 1, no. 2.
- [12] Kotb M F, El-Saadawi M, and El-Desouky E H, 2018, " Over current protection relay using Arduino Uno for future renewable electric energy delivery and management system", Euro. J. of Elect. Eng. & Comp. Sci., vol. 2, no. 5.

### \*Corresponding author

Ahmed M. T. Ibraheem Al-Naib,  
 Dep. of Electrical Power Technologies Eng., Engineering Technical College, Mosul, Northern Technical University, Iraq  
 e-mail: [ahmed\\_alnaib2018@ntu.edu.iq](mailto:ahmed_alnaib2018@ntu.edu.iq)

- [13] Jenifer A, Bharathi B R, and Shanthi Mounika B, 2018, "Monitoring and protection of distribution transformer using GSM module", *Int. J. of Eng. and Tech.*, vol. 4, no. 1.
- [14] Akshay R. Thakare, Sneha S. Yadaw, Pushkar I. and et.al, 2018, " Protection and monitoring of transformer using Arduino", *Int. J. for Research in App. Sci. & Eng. Techno.*, vol. 6, no. 2.
- [15] Mohammed, L. A., Husain, T. A., & Ibraheem, A. M. (2021). Implementation of SHE-PWM technique for single-phase inverter based on Arduino. *International Journal of Electrical and Computer Engineering*, 11(4), 2907.
- [16] Hamad, B. A., Ibraheem, A. M., & Abdullah, A. G. (2020). Design and practical implementation of dual-axis solar tracking system with smart monitoring system. *Prz. Elektrotech*, 1(10), 153-157.
- [17] Khaleel, K., Atyia, T. H., & Al-Naib, A. M. I. (2022). Design and Development of Real-Time Data Acquisition of Photovoltaic Panel Parameters via IoT. *NTU Journal of Renewable Energy*, 3(1), 1-8.
- [18] Hamad, B. A., & Ibraheem, A. M. (2021). Design and Implementation of a Dual-Axis Solar Tracking System STS. *Northern Technical University Journal of Engineering and Technology*, 1(1), 35-43.
- [19] Ali, A. J., Ibraheem, A. M., & Mahmood, O. T. (2020, February). Design of a smart control and protection system for three-phase generator using Arduino. In *IOP Conference Series: Materials Science and Engineering* (Vol. 745, No. 1, p. 012027). IOP Publishing.
- [20] ABDUALLAH, Zaki Majeed; MAHMOOD, Omar Talal; AL-NAIB, Ahmed MT Ibraheem. Photovoltaic battery charging system based on PIC16F877A microcontroller. *International Journal of Engineering and Advanced Technology (IJEAT)*, 2014, 3.4: 27-31.
- [21] Alsaqal, Laith M. Akram, Ahmed MT Ibraheem Alnaib, and Omar Talal Mahmood. "Comparison of multiple modulation techniques for various topologies of multilevel converters for single phase AC motor drive." *Int J Pow Elec & Dri Syst* ISSN 2088.8694 (2019): 8694.
- [22] Alnaib, Ahmed, Nashwan Sultan, and Omar Mahmood. "Design a Fuel cell based drive DC motor for an electric vehicle applications." *International Journal of Engineering & Technology* 7.4 (2018): 2081-2087.
- [23] Ibraheem, Ahmed MT, Laith A. Mohammed, and Qusay H. Ali. "Implementation of Phase Shifted Carrier Modulation Technique for Cascaded Five-Level Inverter Using FPGA." *IOP Conference Series: Materials Science and Engineering*. Vol. 881. No. 1. IOP Publishing, 2020.
- [24] Altaee, O. T. M., & Alnaib, A. M. I. (2018). Comparative Analysis of Various Multicarrier Modulation Techniques for Different Multilevel Converters. *Journal of Engineering*, 24(12), 45-59.
- [25] Abdullah, Z. M., Alnaib, A. M. I., & Mahmood, O. T. (2014). Design of Wind Turbine Energy System Based on Matlab/Simulink. *Eng. & Tech. Journal*, 32.
- [26] Ibraheem, Ahmed MT. FPGA Based Three-Phase Sinusoidal PWM Control for Voltage Source Inverter Fed IM. Diss. Master thesis, Technical College/Mosul, 2010.
- [27] Raheem Kareem, P., & MT Ibraheem Alnaib, A. (2018). PEM Fuel Cell Powered Multilevel Converter. *Anbar Journal of Engineering Sciences*, 9(1), 300-307.
- [28] Alnaib, A. M. I. SIMULATION AND CHARACTERISTICS STUDY OF SOLAR PHOTOVOLTAIC ARRAY USING MATLAB/SIMULINK.
- [29] Mahmood, Omar Talal, Nashwan S. Sultan, and Ahmed MT Ibraheem Alnaib. "Design of genetic algorithm controller to fuel cell fed SEIG derived by DC motor." *International Journal of Engineering & Technology* 7.4 (2018): 4141-4145.
- [30] Coran, A. N. N., Mahmood, Z. S., & Kamal, A. E. (2021, October). Classification of Acoustic Data Using the FF Neural Network and Random Forest Method. In *2021 International Conference on Smart Generation Computing, Communication and Networking (SMART GENCON)* (pp. 1-4). IEEE.
- [31] AL-Naib, A. M. I. Speed Control of Three-Phase Induction Motor Based on V/F Technique.
- [32] [40] Nasret, A., & Mahmood, Z. (2019). Optimization and integration of rfid navigation system by using different location algorithms. *International Review of Electrical Engineering (IREE)*, 14(4).
- [33] Mansoor, A. K. Z., Basheer, N. M., & Al-Naib, A. M. WIDE RANGE MODULATION INDEX VARIATION/FPGA BASED SPWM THREE-PHASE INVERTER.
- [34] Al-Naib, A. M. I., & Abdullah, A. G. (2023, March). Practical implementation of modified converter. In *AIP Conference Proceedings* (Vol. 2591, No. 1, p. 040002). AIP Publishing LLC.
- [35] Ahmed M. T. Ibraheem AL-Naib, "Design and Implementation of Five Level Cascaded H-bridge MLI", 3rd Scientific International Conference 2013, Foundation of Technical Education/ Technical College Najaf, PP. 820-829.
- [36] AL-Naib, A. M. I. Analysis of Seven Level Cascaded Multilevel DC-Link Inverter.
- [37] Mahmood, Z. S., Coran, A. N. N., esam Kamal, A., & Noori, A. B. (2021, August). Dynamic spectrum sharing is the best way to modify spectrum resources. In *2021 Asian Conference on Innovation in Technology (ASIANCON)* (pp. 1-5). IEEE.
- [38] Mahmood, Z. S., Coran, A. N. N., & Kamal, A. E. (2018). Dynamic approach for spectrum sharing in cognitive radio. *International Journal of Engineering & Technology*, 7(4), 5408-5411.
- [39] Nasret, A. N., Noori, A. B., Mohammed, A. A., & Mahmood, Z. S. (2021). Design of automatic speech recognition in noisy environments enhancement and modification. *Periodicals of Engineering and Natural Sciences*, 10(1), 71-77.
- [40] Mahmood, Z. S., Kadhim, I. B., & Nasret, A. N. (2021). Design of rotary inverted pendulum swinging-up and stabilizing. *Periodicals of Engineering and Natural Sciences*, 9(4), 913-920.

---

**\*Corresponding author**

Ahmed M. T. Ibraheem Al-Naib,  
Dep. of Electrical Power Technologies Eng., Engineering Technical College, Mosul, Northern Technical University, Iraq  
e-mail: [ahmed\\_alnaib2018@ntu.edu.iq](mailto:ahmed_alnaib2018@ntu.edu.iq)